



**Products to Make
Your Job Easier**

**PHS West
INC**

Product Specification - 19000 Series Ergonomic Lifter



The 19000 Series **LIFT-O-FLEX®** ergonomic lifter offers dynamic load handling characteristics for heavy load capacities. The 19000 series has a lift capacity of 350-lbs and the 19500 provides for a lift capacity of 500-lbs. Both models provide expanded flexibility in equipment selection to better fill your ergonomic lifting requirements.

The 19000 series lifters use many of the same basic lifter components. This allows for inter-changeability between lifters permitting the customer to satisfy ergonomic lifter requirements while maintaining the ability to adapt the lifter to meet the challenge of meeting tomorrow's lifter needs today without incurring the cost of complete replacement.

Each lifter is comprised of modules for easy assembly. The legs are separate and mount to the intermediate section with 8 bolts each side. Casters are mounted to the front and a single swivel caster at the rear. A foot operated rear central braking system is used on the lifter. The three (3) position braking system is used to enhance safety and lifter workability. (Rear legs locked in trailing position for easy transport-independent swivel and locked for stationary positioning).

The intermediate section is provided with a lift motor for powering the mast slide for easy and safe movement of the end-effector. The mast is totally enclosed and is provided with a ball screw for smooth up and down DC powered movement. A slip clutch on the down movement provides for safe load handling.

The electronic power pack can be provided with either standard or heavy-duty batteries depending on application usage. Power packs are also exchangeable allowing for multi-shift operation. Current limiting (no limit switches) provide for load limiting and stops. The handlebar is adjustable by the operators to achieve ergonomic operation. This along with the detachable remote controller provides the operator with control over load handling functions.



**Products to Make
Your Job Easier**

**PHS West
INC**

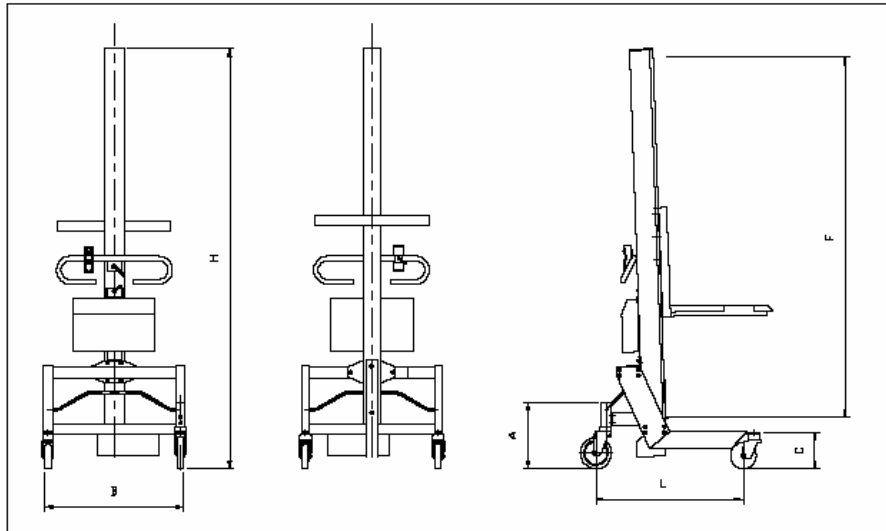

NOTE: Custom Lift-O-Flex® solutions can be designed specifically for your application

Lift-O-Flex® 19000 Series Dimensions

	<u>19000</u>	<u>19500</u>
H. Lift Mast Std. 76.75", Lift Stroke	54"	49.75"
Lift Mast Long 96.5", Lift Stroke	73.75"	69.5"
Lift Mast X-Long 116.25", Lift Stroke	93.25"	89"
L. Wheel Base Std.	28.5"	38.25"
Wheel Base Long	34.5"	
Wheel Base X-Long	40.5"	
Low Built-Standard-Fixed Front-3.5"	34"	40"
Low Built-Long-Fixed Front-3.5"	40"	
Low Built-X-Long-Fixed Front-3.5"	45.75"	
Low Built-Dual Swivel-4.5"	34.5"	39.5"
B. Inside Width:		
Standard	23.5"	23.5"
Narrow	18.5"	18.5"
Wide	33.5"	33.5"
A. Rear Post Height	12.5"	12.5"
C. Front Leg Height-Single Swivel-Std	7"	7"
Front Leg Height-Fixed Wheel Low Built 3.5"	3.5"	3.5"
Front Leg Height-Dual Swivel-Low Built 4.5"	4.5"	4.5"

Lift-O-Flex® 19000 Series Lifter

	<u>19000</u>	<u>19500</u>
Lift Capacity	350-lbs	500-lbs
Weight	170-lbs	190-lbs
Battery	Lead Gel Cell	
Battery Capacity	24V, 16 AHR/32 AH	
Battery Charger Output	24V, 5 Amp	
Charge Time	6-8 Hours	
Lift Speed-19000	Slow: 2.5"/Sec. Fast: 4"/Sec.	
Lift Speed-19500	Slow: 1.25"/Sec. Fast: 2"/Sec.	
Noise Level	>70dB(A)	
Front Wheel	5" Diameter	
Rear Wheel	6" Diameter	
Low Built-Front Wheel	3.25"/3" Diameter	
Wheel Material	Polyurethane	

Rev 3/16/05